

FlexiROC D65

Surface drill rig for quarrying and mining

FlexiROC D65 hole diameter: 110–203 mm (4.3"–8")



A rig you can rely on

The FlexiROC D65 surface drill rig from Epiroc is the perfect balance between productivity and efficiency. A proven and dependable rig for DTH drilling in mining and large quarry applications, the FlexiROC D65 is rugged and multifunctional. It's built to take on the toughest drilling demands and is ready to exceed your expectations.

+ Main benefits

Productive and efficient thanks to impressive DTH performance

Broad utilization due to flexibility and multi-task capability

Proven and rugged to get the job done



Built for high efficiency mining, the DTH hammer fitted to the FlexiROC D65 benefits from a precisely matched compressor.



Whether working in quarries or open pit mines, the FlexiROC D65 will deliver straight, smooth holes — shift after shift.



When equipped with the standard feed option, the FlexiROC D65 is capable of handling an even wider range of jobs with ease, including drilling de-watering holes.



The feed-system ensures smooth and uniform movement

Superior visibility during collaring and tube handling

The cabin is ROPS and FOPS-approved and mounted on a protective plate

Designed to meet the latest emissions regulations with Tier 3 and Tier 4 Final/ Stage 5 engines



Discover more about the FlexiROC D65.

A flexible and versatile rig which delivers a fast return on investment

The FlexiROC D65 is a reliable and versatile machine. It offers a total drilling solution which is able to perform various applications such as production drilling, pre-split holes, de-watering holes and in-pit grade control when equipped with the Reverse Circulation (RC) option.



+ Built for high efficiency mining

Whether operating in quarries or open pit mines, the FlexiROC D65 delivers straight and smooth holes. This rig has plenty of air available to keep the hole clean for easy charging. The highly efficient DTH hammer is matched precisely with the compressor to provide optimum performance. The FlexiROC D65 from Epiroc is the result of decades of experience and know-how gained from the toughest mining and quarrying conditions.



+ Designed through evolution

At Epiroc, we never stop learning. We believe it's important to talk to you – our customers. As a result, we are constantly evolving and learning new ways to get the job done better, more efficiently and above all, safely. Continuous customer feedback and our years of experience from all over the world have assisted in developing the FlexiROC D65. The rig is designed to perform shift-after-shift in the most demanding mining applications.



+ Flexible and versatile

Delivering value across a broad spectrum of applications is important for a fast return on investment. The FlexiROC D65 is available with both standard or long feeds and is capable of drilling at a wide range of angles. This machine is ready for work in any almost any situation and is designed to help ensure your profitability.

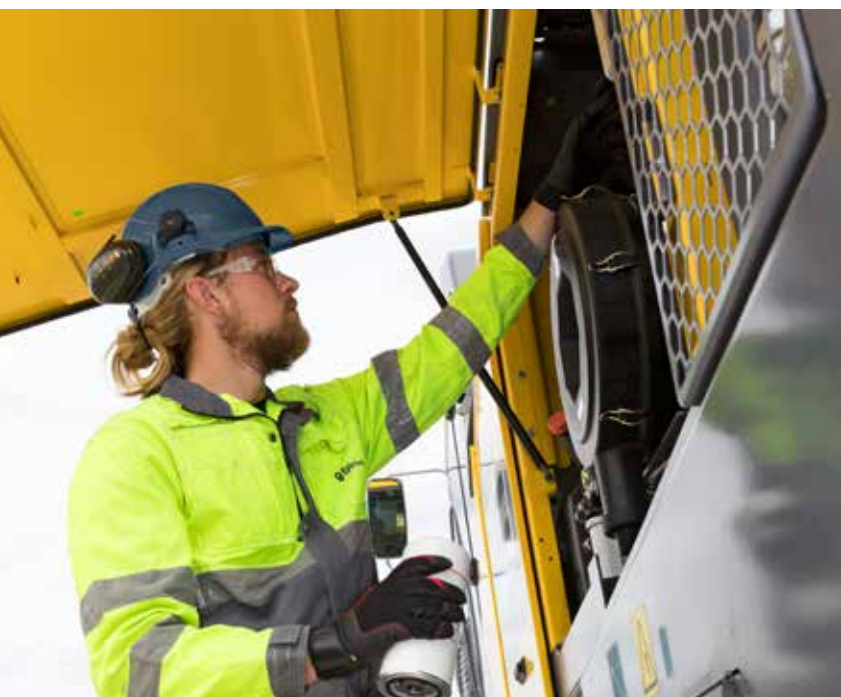

A comprehensive service offering

Even the best equipment needs to be serviced regularly to make sure it sustains peak performance. An Epiroc service solution offers peace of mind, maximizing availability and performance throughout the lifetime of your equipment. We focus on safety, productivity and reliability.

By combining genuine parts and an Epiroc service from our certified technicians, we safeguard your productivity – wherever you are.

Technical specifications

Main components

- Crawler type two speed undercarriage with track oscillation system
- Tier 4 Final/Stage 5 or Tier 3 CAT turbo-charged diesel engine
- Atlas Copco screw-type high pressure compressor
- ROPS and FOPS-approved operator cabin with rubber vibration dampers
- Single section boom system
- Aluminum profile feed beam
- Toe-hole drilling capability (standard feed version)
- Carousel type tube handling system
- Break-out table with pressure regulating kit
- Hydraulic operated rotary head
- Built for use with 4", 5", and 6" down-the-hole hammers
- Service hand lights inside canopy

Hole range & length (recommended)

		Metric	US
FlexiROC D65	COP 44 GoldCOP 54 Gold, COP 64 GoldCOP 66	110-203 mm	4.31'-8'
Hydraulic tube handling system for max hole length, with 5 m (16,4') tubes – standard feed			
FlexiROC D65	Ø 89-114 mm (3.5" - 4.5") drill tubes	45 m	148'
FlexiROC D65	Ø 127-140 mm (5" - 5.5") drill tubes	25 m	82'
Hydraulic tube handling system for max hole length, with 6 m (20') tubes and a 7.5 m starter tube – long feed			
FlexiROC D65	Ø 89-114 mm (3.5" - 4.5") drill tubes	55.5 m	182'
FlexiROC D65	Ø 127-140 mm (5" - 5.5") drill tubes	31.5 m	103'
Single pass drilling, max hole length			
FlexiROC D65 standard feed		5.4 m	18'
FlexiROC D65 long feed		7.5 m	25'

RHS 140 is standard on the FlexiROC D65. It can handle pipe sizes 76, 89, 102, 114, 127, 140 mm. With the standard feed, RHS 102 is available as option and can handle pipe sizes 76, 89, 102 mm.

Engine

FlexiROC D65	Metric	US
CAT C15, turbo-charged, diesel engine, Tier 4 Final /EU Stage 5 (multi-certified for US and EU markets) or Tier 3/ stage IIIA - power rating at 1800 rpm	403 kW	540 HP

Compressor

FlexiROC D65	Metric	US
Atlas Copco XRX 10 two-stage screw type compressor		
Working pressure, max	30 bar	435 psi
FAD (30 bar)	470 L/s	995 cfm

Rotary head

	Connection thread	Max (rpm)	Max torque, drilling		Suitable for DTH-hammer
			Metric	US	
DHR6 H 45	API 2 3/8" REG, box	137	1839 Nm	1356 lbf	COP 44 Gold (COP 54 Gold)
DHR6 H 56	API 3 1/2" REG, box	107	2353 Nm	1735 lbf	COP 54 Gold COP 64 Gold COP 66
DHR6 H 68	API 3 1/2" REG, box	68	5800 Nm	2712 lbf	COP 64 Gold COP 66
DHR6 H 78	API 3 1/2" REG, box	54	6600 Nm	3417 lbf	COP 64 Gold COP 66

Carrier

	Metric	US
Tramming speed, max	3.2 km/h	2.0 mph
Traction force, max	138 kN	31020 lbf
Ground clearance	405 mm	16"
Track oscillation	±10°	

Hydraulic system

Hydraulic oil cooler	Metric	US
Max ambient temperature	50 °C	122 °F
Pumps		
Axial piston pump (1)	240 L/min	63 gal/min
Gear pump (2)	111 L/min	29 gal/min
Gear pump (3)	63 L/min	16.6 gal/min
Gear pump (4)	39 L/min	10.3 gal/min
Gear pump (5)	31 L/min	8.2 gal/min
Gear pump (6)	31 L/min	8.2 gal/min
Return and drainage filters (2 x 3 filters)		
Filtration rate 20 µm absolute	20 µm absolute	

Aluminum feed

Aluminum profile feed with hose guide and double drill tube support with break-out table and movable lower guide/dust hood	Metric	US
Feed rate, max	0.9 m/s	177 ft/min
Feed force, max	40 kN	8992 lbf
Tractive pull, max	50 kN	11240 lbf
Feed motor size	2099 cc	0.6
Chain size	45 mm	1.8"
Long Feed		
Feed extension	1150 mm	45.3'
Travel length	7540 mm	296.8'
Total length	11600 mm	456.7'
Standard Feed		
Feed extension	1900 mm	74.8'
Travel length	5400 mm	212.6'
Total length	9400 mm	370'

Dust collector

DCT 320 including pre-separator	Metric	US
Filter area	32 m²	344 sq.ft
Suction capacity at 500 mm wg	1270 L/s	2690 cfm
Suction hose diam	203 mm	8"
Cleaning air pressure, max	8 bar	116 psi
Cleaning air consumption	2-4 l/pulse	0.06-0.12 cfm/pulse
Number of filter elements		32 pcs

Technical specifications

Electrical system

Voltage	24 V
Batteries	2 x 12 V 235 Ah
Alternator	28 V 95 Ah
Work lights, front	4 x 70 W
Work lights, rear	2 x 70 W
Work lights, feed	2 x 70 W
Warning lamp and reverse buzzer	

Volumes

	Metric	US
Hydraulic oil tank	380 l	100 US gal
Hydraulic system, total	600 l	158 US gal
Compressor oil	63 l	12 US gal
Diesel engine oil	44 l	11.6 US gal
Diesel engine, coolant, Tier 3	65 l	17 US gal
Diesel engine, coolant, Tier 4	110 l	29 US gal
Diesel engine, fuel tank	1050 l	277 US gal
Traction gear	3 l	0.8 US gal
Lubrication tank (HECL)	20 l	5.3 US gal
DEF fluid tank (Tier 4 final only)	34 l	9 US gal

Cabin

- ROPS and FOPS-approved with rubber vibration dampers
- Rig inclination indicator
- 2 x wipers with washer
- Clear laminated glass (front and roof windows)
- Outlet socket, 24 V
- Clear toughened glass (side and rear windows)
- Prepared for CD, radio or DVD
- Fully adjustable operator seat
- Electric combined engine/inclination hole depth instrument
- Adjustable foot rest, rear view mirror, cabin light
- Air conditioning and heating system

A selection of options

Carrier

- Hydraulic support leg
- Protection hand rails on top of canopy
- Wide body kit
- Halogen work light covering feed support, transport position
- LED work lights
- Heavy duty air intake filters for engine and compressor
- Combined warning sound and warning light, beacon type
- Manually or automatic ansul fire extinguisher system
- Tropical kit for 55° ambient temperature
- Electric pump for filling hydraulic oil
- Electric fuel filling pump
- Fast fuel filling system
- Cold weather kit +5° C to -25° C, including diesel engine heater
- Cold weather kit -25° C and below, including diesel engine heater and ether start

Cabin

- Rubber ladder for left hand side
- Clear laminated glass (front and roof windows)
- Tinted toughened glass (side and rear windows)
- Sun shade kit
- Electric heated seat
- Radio/CD or Radio/DVD
- Reverse camera with cab-mounted monitor
- Rod Handling System 102 (only short feed)
- Screw sampler
- Service winch with jib boom mounted on the feed
- Wide feed foot
- Protective guard, according to EN16228

Water mist system

- Water mist system, pump, one or two 400 l water tanks
- Arc tic-ready water mist system, pump, one or two 400 l water tanks

Lubrication

- Central lubrication system, type Lincoln
- Thread lubrication, spray system
- Artic hydraulic oil, VG 32
- Tropical hydraulic oil, VG 68
- Biological hydraulic oil, VG 46

Hole and Inclination systems

- Aiming unit function to standard instruments
- GPS compass aiming unit
- Laser receiver

Automation and software

- Production log for ROC Manager

Parts and Services products

- ROC Care
- CERTIQ satellite based drill rig monitoring system (only in combination with a written service agreement)

Delivered equipment, not mounted

- First 50 hours service kit for compressor
- Tool kit for rotary head with fixed spindle sub
- Tool kit for rotary head with floating spindle sub

Maximum drilling angles with feed positioned towards cabin

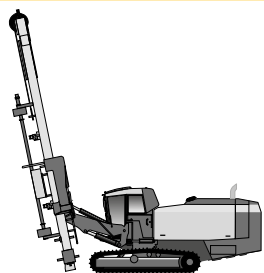

Horizontal body	
FlexiROC D65 LF	15°
FlexiROC D65 SF	22°

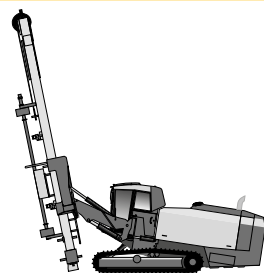

Backwards tilt body: 10°	
FlexiROC D65 LF	18°
FlexiROC D65 SF	25°

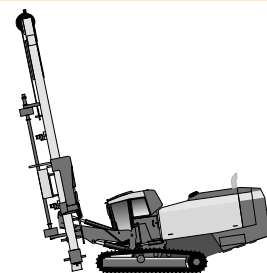

Front tilt body: 10°	
FlexiROC D65 LF	11°
FlexiROC D65 SF	20°

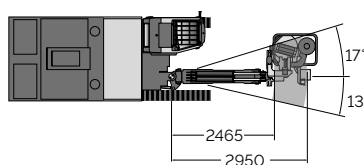

Horizontal reach (mm) with long feed

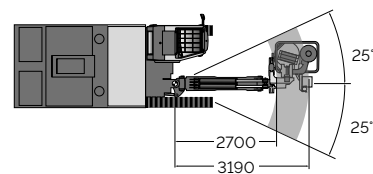

Horizontal reach (mm) with standard feed

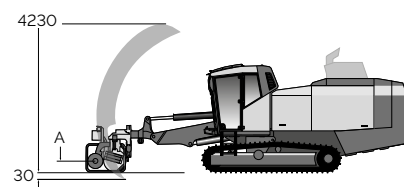

Toe-hole drilling (mm) (standard feed only)

Technical specifications

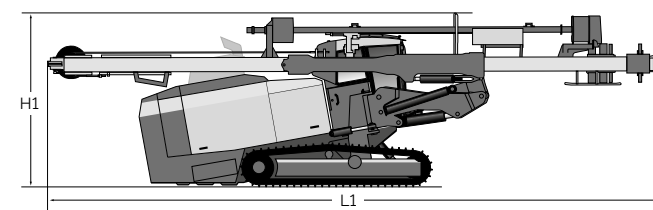

Feed dumped (long feed)

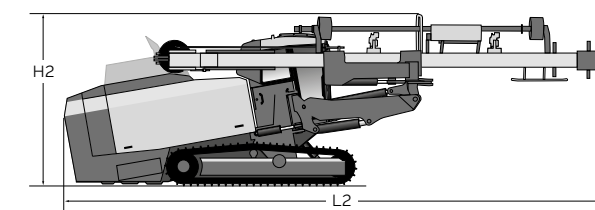

Feed dumped (short feed)

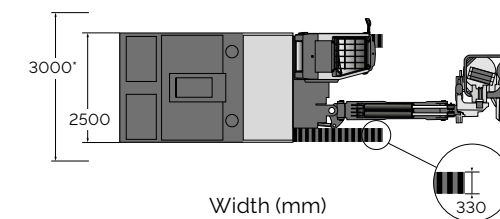

Width (mm)
(*with wide kit option)

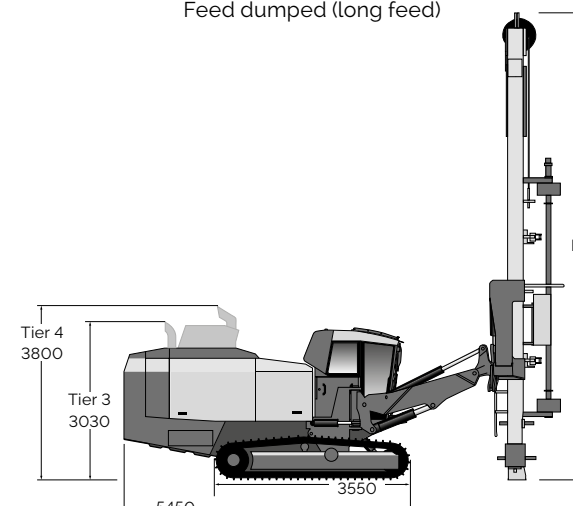

Height and length (mm)

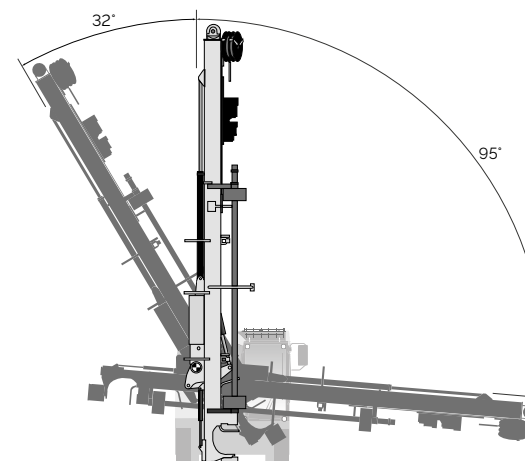

Feed swing angles - standard feed

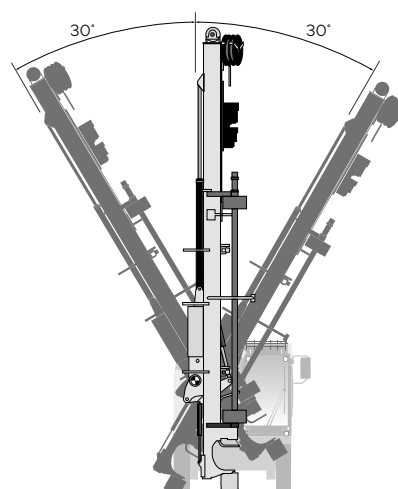

Feed swing angles - long feed

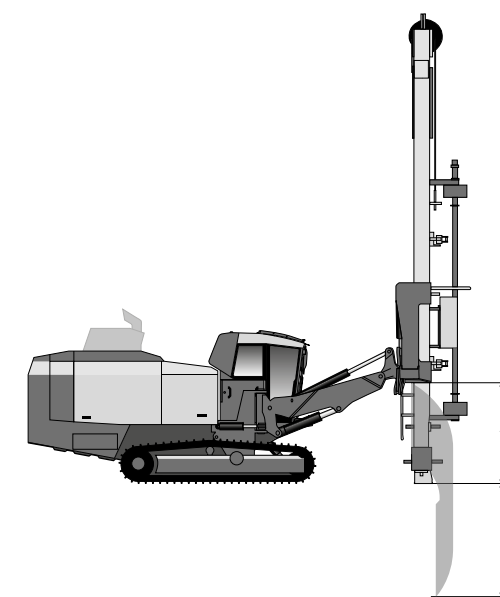

Vertical reach

	A (Metric)	B (Metric)	A (US)	B (US)
Long feed	582 mm	2277 mm	23'	90'
Standard feed	1040 mm	2659 mm	41'	105'

Height and length

Long Feed (LF) dumped		Metric	US
Height (H1)		3 500 mm	138'
Length (L1)		11 600 mm	457'
Standard Feed (SF) dumped		Metric	US
Height (H2)		3 500 mm	138'
Length (L2)		11 350 mm	447'
Feed height		Metric	US
Long Feed (H3)		11 600 mm	457'
Standard Feed (H3)		9 400 mm	370'

Weight

Standard unit excluding all options and drill rods	Metric	US
FlexiROC D65 long feed	23 700 kg (T3)	52 250 lb
	24 100 kg (T4)	53 130 lb
FlexiROC D65 standard feed	22 600 kg (T3)	49 820 lb
	23 000 kg (T4)	50 700 lb



9868 0298 01a 2021-01 Örebro, Sweden. Legal Notice © Copyright 2021, Epiroc Rock Drills AB, Örebro, Sweden. All product names in this publication are trademarks of Epiroc. Any unauthorized use or copying of the contents or any part thereof is prohibited. Illustrations and photos may show equipment with optional extras. No warranty is made regarding specifications or otherwise. Specifications and equipment are subject to change without notice. Consult your Epiroc Customer Center for specific information.

United in performance. Inspired by innovation.

Performance unites us, innovation inspires us, and commitment drives us to keep moving forward. Count on Epiroc to deliver the solutions you need to succeed today and the technology to lead tomorrow.
epiroc.com

